

9/16-18UNF-2B Oil port size

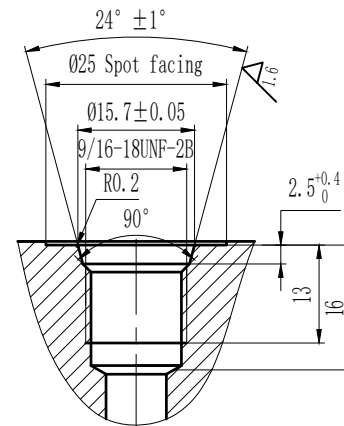

Technical requirement

- 1, before assembly to make sure that each part is qualified, Ensure cleanliness within NAS9 level;
2. Assembly shall be carried out in accordance with assembly operation instructions;
- 3, after assembly on the factory test bench according to the handle of the factory test standard inspection, Affixed a qualified mark after passing;
4. 9/16-18UNF rubber plug for oil port of qualified products Plug up to prevent flying dust.

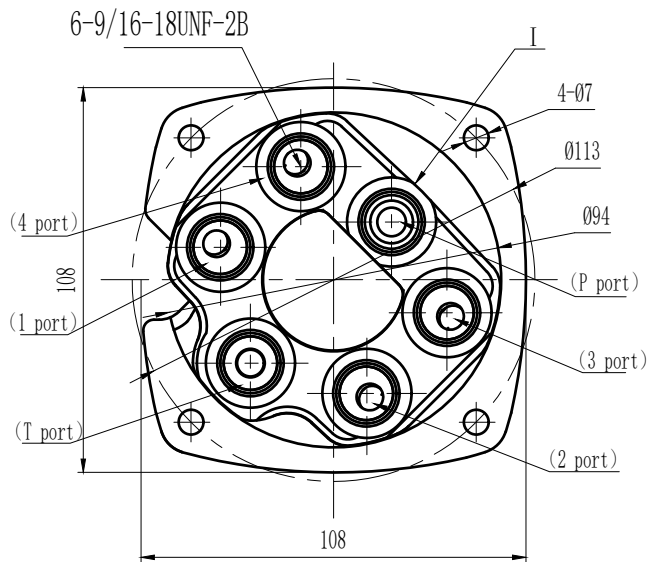

Model marking content  
 XXXXXXXX Our model  
 XXXXXX Ourserialnumber

						FPJ-N30-X0-X1			Ningbo Flag-up Hydraulic
mark	number	changed	file number	signature	date	pattern mark	weight	proportion	
designer				approver					
inspector								1:1.5	
craft									
standard				date		version		visual angle	
									Handle (Cutter) 810900152