

Model marking content
 XXXXXXXX Our model
 XXXXXX Our serial number

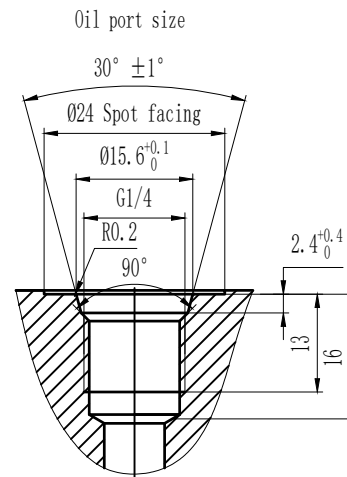
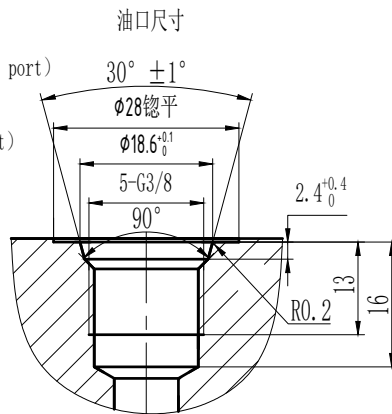
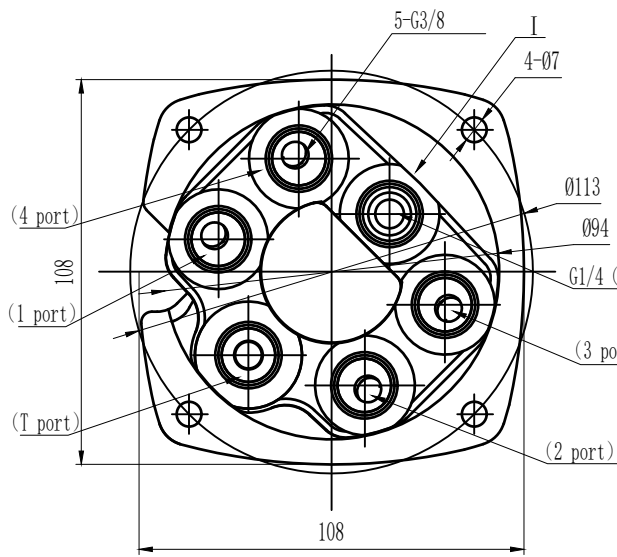

Technical requirement

- 1, before assembly to make sure that each part is qualified, Ensure cleanliness within NAS9 level;
2. Assembly shall be carried out in accordance with assembly operation instructions;
- 3, after assembly on the factory test bench according to the handle of the factory test standard inspection, Affixed a qualified mark after passing;
4. G1/4 and G3/8 for oil ports of qualified products Plastic plugs are plugged to prevent flying dust.

						FPJ-N1-X0-X0			Ningbo Flag-up Hydraulic Handle (Kobelco)	
mark	number	changed file number	signature	date		designer	approver	pattern mark		weight
						inspector				1:1.5
						craft				
						standard	date	version	visual angle	
										810900141