

I00090918

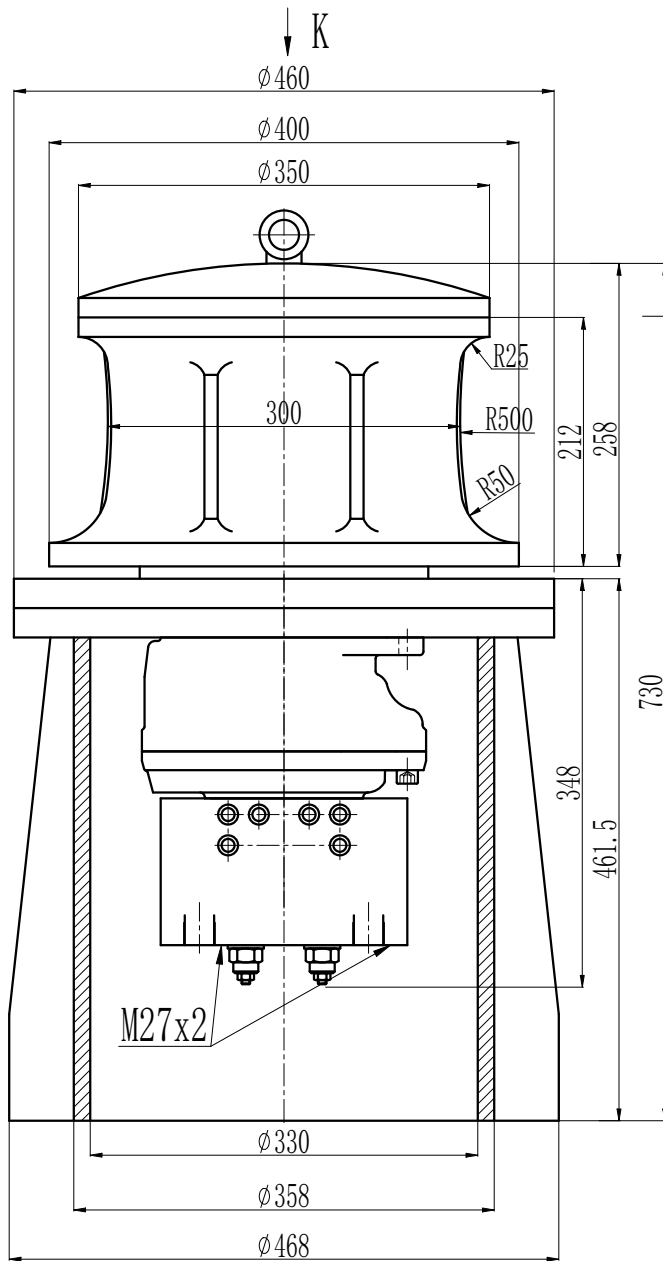

K-direction

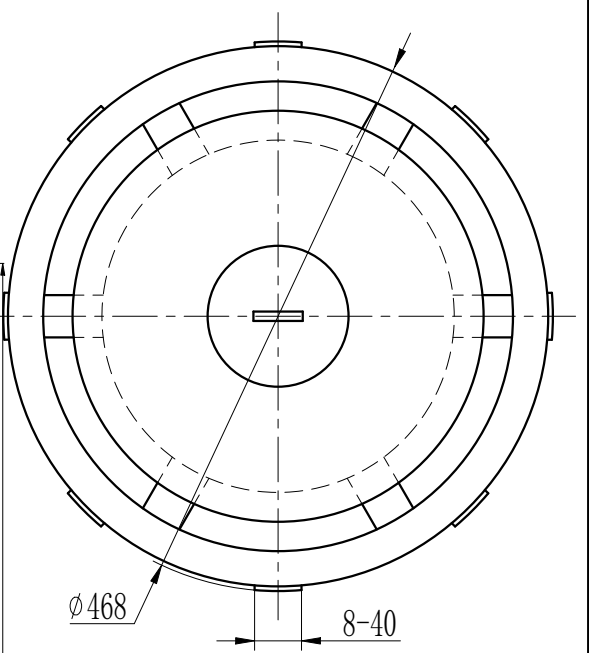

Hydraulic schematic diagram

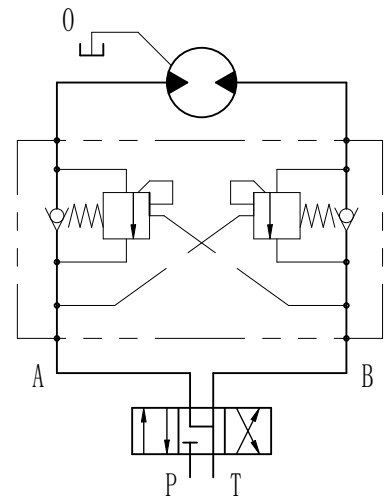

Winch technical parameters:

model	Rated tension (KN)	Rated speed (m/min)	Anchor chain wheel diameter (mm)	work pressure (Mpa)	Rated working flow (L/min)	total displacement (ml/r)	Transmission ratio	Hydraulic motor model
FJP2.5-20	20	10	24	15.5	19	1727	5.5	FGM1-320D47F602

借(通)用件登记

描 图

描 校

旧底图总号

底图总号

签 字

日 期

mark	number	partition	changed file	signature	date
designer					
inspector					
craft					

FJP2.5-20-24-P-FGM1-320		
pattern mark	weight	proportion
A.0		1:6

Ningbo Flag-up Hydraulic
 flag-up
 2T winch outline drawing
 816050001